

EVOLVE
LIGHTING

THE SCOUT FLOODLIGHT

ESSENTIAL SERIES FLOODLIGHT



UP TO
150lm/W
SYSTEM EFFICACY

MASSIVE
70%
ENERGY SAVINGS

LONG
54,000+
HOURS LIFETIME

UP TO
22,500lm
OUTPUT

SCOUT FLOODLIGHT RANGE

High performance, high efficiency, high quality

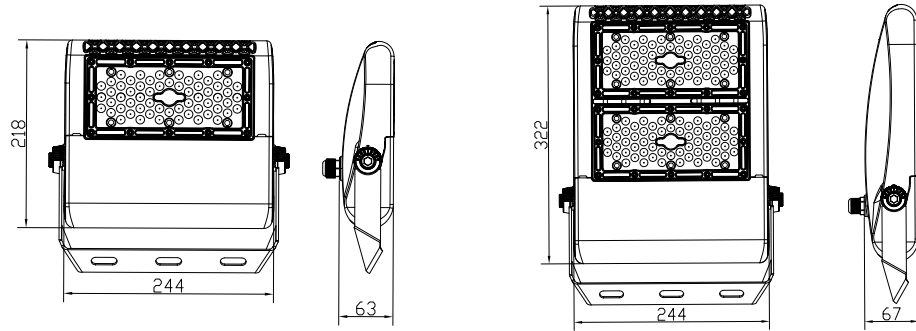

PRODUCT CODE	SCOUT50*	SCOUT70*	SCOUT100*	SCOUT150*
Wattage	50W	70W	100W	150W
Lumen Output	6,500lm**	10,500lm**	15,000lm**	22,500lm**
Luminous Efficacy	130lm/W		150lm/W	
CCT		4000K / 5000K		
CRI		>70		
Beam Angle		30°, 60°, 90°, 85x135°		
Lifetime @L70		>54,000hrs		
IP Rating		IP67		
IK Rating		IK10		
Input Voltage		200-240Vac 50-60Hz PF≥0.95		
Fitting Colour		Graphite Grey (RAL 7024) / White (RAL 9003)		
Coating		Corrosion-resistant Epoxy-Polyester hybrid powder coat		
Bracket		Galvanized Iron (316 Stainless Steel available)		
Warranty		5 Year product replacement		

* Please see website for full codes | ** Outputs change depending on the beam angle

